

LiftMaster®

WATERPROOF KEYPAD/PROXIMITY READER

MODEL KPR2000

TABLE OF CONTENTS

INTRODUCTION	2	PROGRAMMING	5
FEATURES	2	CONFIGURE THE KPR2000.....	5
ACCESSORIES	2	PROGRAM CARDS AND PINS.	6
CARTON INVENTORY	2	ADVANCED PROGRAMMING	7
SPECIFICATIONS	2	PANIC CODES	7
ONE YEAR LIMITED WARRANTY	2	ALARM.....	8
INSTALLATION	3	SOUND & LIGHT INDICATION.....	8
INSTALL THE KPR2000.....	3	RESET THE KPR2000	8
CHOOSE AN OPERATION MODE.....	3	ERASE ALL CODES	8
WIRING	4		
WIRE THE KPR2000.....	4		

INTRODUCTION

The LiftMaster KPR2000 is a single entry multi-function Access Controller with integrated keypad and card reader. It is designed and manufactured to perform in a wide range of indoor, outdoor, and harsh environments.

The KPR2000 supports up to 2000 users in multiple access configurations (Card Only, Card or PIN, or Card + PIN). The built in 125 KHz card reader supports HID 26 bit Wiegand and 30 bit Sentex Wiegand proximity card formats. The KPR2000 offers advanced programming features like; block enrollment, advanced relay programming, and Panic PINs/Cards (which open the entry and set off the alarm).

Features

- Waterproof (IP68) (meets or exceeds N4)
- Vandal Resistant Enclosure
- Backlit Keypad
- Multi-color LED status display
- Integrated Alarm Buzzer & Output
- One Programmable Relay Output
- Stand Alone or Pass-Through Operation
- 2000 Users (Card/PIN/Card+PIN)
- 10 Panic Card/PIN Codes
- Low power consumption (50mA)
- Anti-Tamper Alarm
- Latch Mode to hold door or gate open

Accessories

- Model PEDS44 Low Profile Access Pedestal
- Model PEDAD 4 x 4 Pedestal Adaptor
- Model PS12V2A 12 Vdc, 2 Amp Power Supply

Carton Inventory

NOT SHOWN: User's Manual

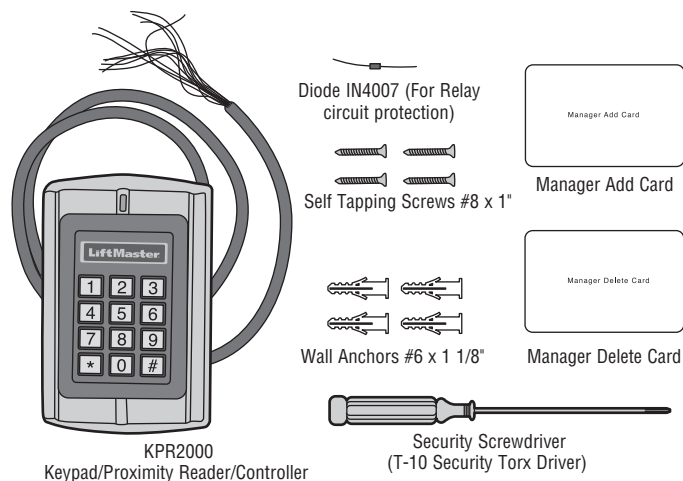

Specifications

User Capacity	2000 Cards/PINS plus 10 Panic Cards/PINS
Operating Voltage	12 ~ 24 Vdc
Idle Current	~ 50mA
Active Current	~ 80mA
Keypad	12 Key (3x4)
Proximity Card Reader	HID 26 bit and 30 bit (Sentex)
Radio Technology	125 KHz Industry Standard Proximity Card
Read Range	1 inch - 2.5 inches
Wiring Connections	Relay Output, REX, DOTL, Alarm, Wiegand (in/out)
Relay	One (NO, NC, Common)
Adjustable Relay Output Time	1 ~ 99 Seconds (5 seconds default)
Adjustable Alarm Output Time	0 ~ 3 Minutes (1 minute default)
Lock Output Load	1 Amp Maximum
Alarm Output Load	1 Amp Maximum
Wiegand Interface	HID Wiegand 26 and 30 bit Format Input & Output
Environment	Meets or exceeds IP68
Operating Temperature	-20°C ~ 60°C, or -4°F ~ 140°F
Operating Humidity	10% ~ 90% Non-Condensing
Physical	Zinc-Alloy Enclosure
Surface Finish	Powder Coat
Dimensions	L:128mm x W:82mm x D:28mm
Unit Weight	1 Pound
Shipping Weight	1.4 Pounds

One Year Limited Warranty

The Chamberlain Group, Inc. warrants to the first consumer purchaser of this product that it is free from defect in materials and/or workmanship for a period of 1 year from the date of purchase.

This device complies with Part 15 of the FCC rules. Operation is subject to the following two conditions: (1) This device may not cause harmful interference, and (2) this device must accept any interference received, including interference that may cause undesired operation.

INSTALLATION

1 Install the KPR2000.

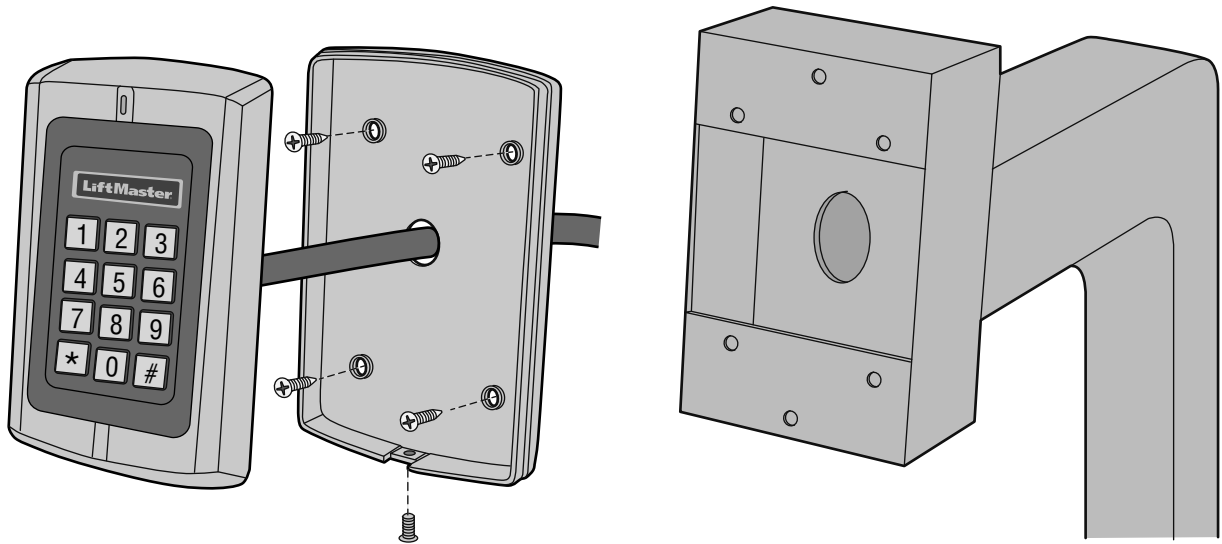

2 Choose an Operation Mode.

STAND ALONE OPERATION

The KPR2000 functions as a complete access control system. The user database is stored in non-volatile memory, reads the PINs and card codes, performs the authentication, and grants and monitors access to the property or device. In Stand Alone Operation there are three different Access Configurations listed below:

- **Card or PIN (Default):** The User must present a valid Wiegand Card to the KPR2000 or enter their PIN code followed by the # key, in order to be granted access.
- **Card Only:** The User must present a valid Wiegand Card to the KPR2000 in order to be granted access. The facility code and the ID number are both read and validated as one block of Wiegand data.
- **Card + PIN:** The User must first present a valid Wiegand Card to the KPR2000 and then enter their PIN code followed by the # key, in order to be granted access.

PASS-THROUGH OPERATION

The KPR2000 passes all keypad and card reader Wiegand data to an external controller. The KPR2000 should be in the "Card or PIN" access configuration for pass-through operation.

IMPORTANT NOTE: Both modes of operation support Auto User ID generation (simplest method) and manual entry of user ID.

WIRING

3 Wire the KPR2000.

Wire Insulation Color	Wiring Function	Notes
Basic Stand Alone Wiring		
Red	Power +	12~24 Volts DC Regulated Power Input
Black	Power -	12~24 Volts DC Regulated Power Input
Pink	Power -	Ground Conductor
Blue	Relay NO	Normally Open Relay Output (Install diode provided)
Purple	Relay Common	Common Connection for Relay Output
Orange	Relay NC	Normally Closed Relay Output (Install diode provided)
Pass-Through Wiring (Wiegand Master and Remote)		
Green	Data 0	Wiegand Output (Pass-through)/Input (Stand Alone) Data 0
White	Data 1	Wiegand Output (Pass-through)/Input (Stand Alone) Data 1
Pink	Ground	
Advanced Input and Output Features		
Yellow	REX	Request To Exit (REX) Input
Gray	Alarm Output	Negative contact for Alarm
Brown	Contact Input	Door/Gate Contact Input (Normally Closed)

WIRING EXAMPLES:

Gate/Door Operator or Fail-Secure Strike

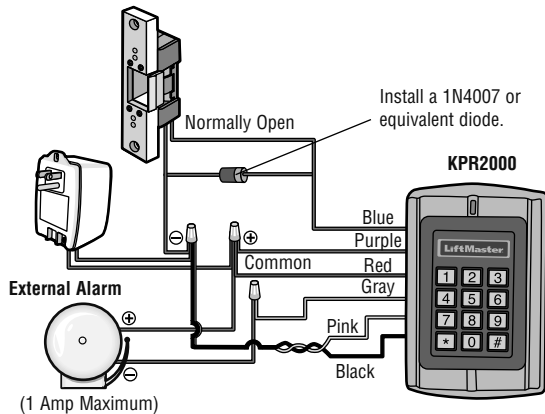

Magnetic Lock or Fail-Safe Strike

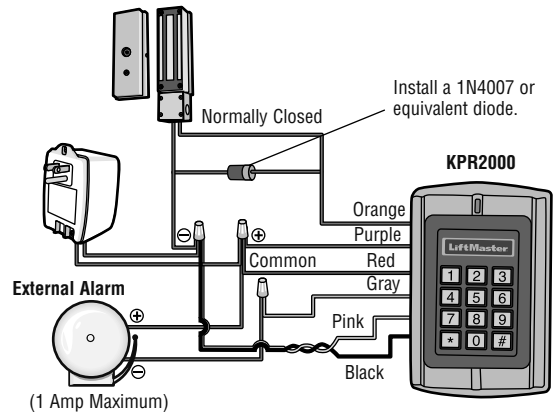

Networking Two KPR2000 Units or Connecting to an Access Control System

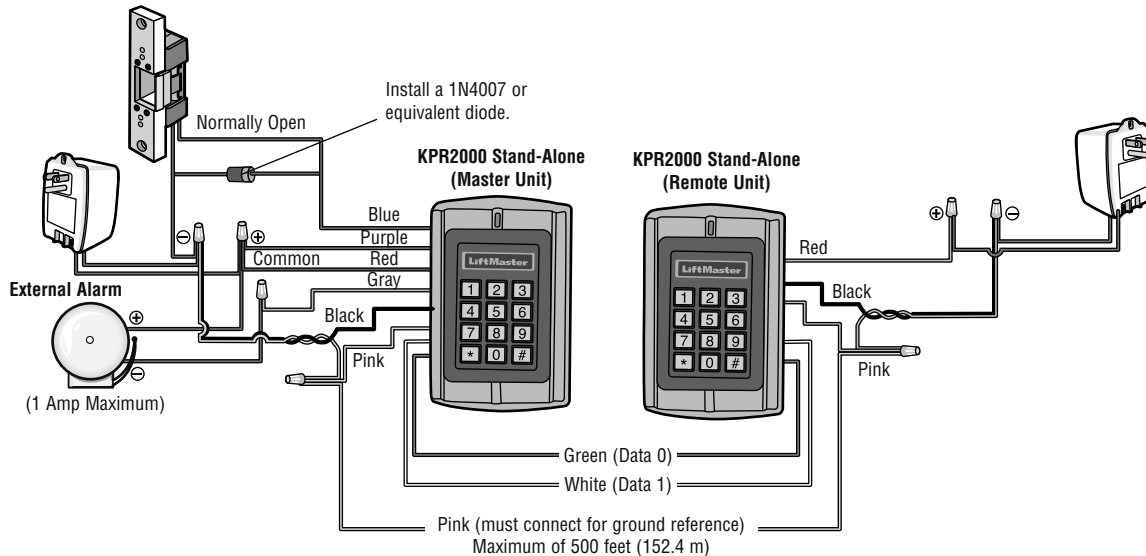

PROGRAMMING

4 Configure the KPR2000.

Change the configure settings according to your application (optional). Multiple configuration settings can be changed at one time: enter program mode, change desired settings, then exit program mode.

SET MASTER CODE

The 6 digit Master Code is used to prevent unauthorized access to the system. To interface with the KPR2000, the manager will need a Master Code (factory default code: 888888). We highly recommend immediate update and recording of your Master Code.

Programming Step	Keystroke Combination
1. Enter Program Mode	* (Master Code) #
2. Update Master Code	0 (New Code) # (New Code) #
3. Exit Program Mode	*

SET ACCESS CONFIGURATION

There are 3 types of access configurations for the KPR2000:

- **Card or PIN (Default):** The User must present a valid Wiegand Card to the KPR2000 or enter their PIN code followed by the # key, in order to be granted access.
- **Card Only:** The User must present a valid Wiegand Card to the KPR2000 in order to be granted access. The facility code and the ID number are both read and validated as one block of Wiegand data.
- **Card + PIN:** The User must first present a valid Wiegand Card to the KPR2000 and then enter their PIN code followed by the # key, in order to be granted access.

Programming Step	Keystroke Combination
1. Enter Program Mode	* (Master Code) #
2. Card Only OR	3 0 #
2. Card + PIN OR	3 1 #
2. Card or PIN	3 2 #
3. Exit Program Mode	*

SET RELAY CONFIGURATION

The relay configuration sets the behavior of the output relay on activation.

Programming Step	Keystroke Combination
1. Enter Program Mode	* (Master Code) #
2. Pulse Mode OR	4 (1-99) # <i>The relay time is 1-99 seconds (default is 5 seconds)</i>
2. Latch Mode	4 0 # <i>Sets the relay to ON/OFF latch mode</i>
3. Exit Program Mode	*

SET WIEGAND INPUT/OUTPUT OPTIONS

The KPR2000 offers input and output for industry standard Wiegand devices (refer to Specifications). Default is HID 26 bit.

Programming Step	Keystroke Combination
1. Enter Program Mode	* (Master Code) #
2. Set Wiegand Format	9 (Bit Format) # <i>Bit Format = Valid 2 digit format (example: 26 or 30)</i>
3. Exit Program Mode	*

SET DOOR OPEN TOO LONG (DOTL) ALARM

This setting requires an external sensor input. The alarm output timing can be set from 1-3 minutes (default is 1 minute). Factory default is OFF.

Programming Step	Keystroke Combination
1. Enter Program Mode	* (Master Code) #
2. DOTL Alarm OFF OR	6 0 #
2. DOTL Alarm ON OR	6 1 # <i>(Alarm sounds for 1 minute)</i>
2. DOTL Output Timing	9 (1-3) #
3. Exit Program Mode	*

SET STRIKE-OUT ALARM

The strike-out alarm will engage after 10 failed card/PIN attempts. Factory default is OFF. The strike-out alarm can be set to deny access for 10 minutes after engaging or it can be set to disengage only after entering a valid master code or card.

Programming Step	Keystroke Combination
1. Enter Program Mode	* (Master Code) #
2. Strike-Out OFF OR	7 0 # <i>(Factory default)</i>
2. Strike-Out ON OR	7 1 # <i>Access will be denied for 10 minutes</i>
2. Strike-Out ON	7 2 # <i>Enter Master Code or Valid Card to silence</i>
3. Exit Program Mode	*

SET AUDIBLE AND VISUAL RESPONSE

Factory default is ON.

Programming Step	Keystroke Combination	
1. Enter Program Mode	* (Master Code) #	
2. Control Backlight OR	ON = 7 5 #	OFF = 7 4 #
2. Control LED OR	ON = 7 7 #	OFF = 7 6 #
2. Control Sounds	ON = 7 9 #	OFF = 7 8 #
3. Exit Program Mode	*	

PROGRAMMING

5 Program Cards and PINS.

Programming will vary depending on the access configuration. Follow the instructions according to your access configuration.

GENERAL PROGRAMMING INFORMATION

- **User ID Number:** Assign a user ID number to the access code in order to keep track of the users of access cards or PINS. The user ID number can be any number from 1~2000. **IMPORTANT:** User IDs do not have to be preceded with any leading zeros. Recording of User ID is critical. Modifications to user data require either the card or the User ID be available.
- **Proximity Card:** Any 125 KHz industry standard 26 bit Wiegand Proximity Card.
- **Keypad PIN:** The PIN can be any 4~8 digits between 0000~99999999 (except 1234 which is reserved for factory testing). **IMPORTANT:** PINs less than 1000 **must** be preceded with leading zeros. PINs greater than 9999 do not require any leading zeros.

ACCESS CONFIGURATION: CARD OR PIN & CARD ONLY

ADD USER CARD(S)

Programming Step	Keystroke Combination
1. Enter Program Mode	* (Master Code) #
2. Add Card: Using Auto ID <i>(Allows KPR2000 to assign Card to next available User ID number)</i> OR 2. Add Card: Select Specific ID <i>(Allows manager to define a specific User ID to associate the card to)</i> OR 2. Add Card: Block Learn <i>(Allows manager to add up to 2000 cards to the KPR2000 in a single step †). Takes 2 minutes to program.</i>	1 (Read Card) # <i>Repeat Step 2 for additional user cards</i> 1 (User ID) # (Read Card) # 5 (User ID) # (The first card number) # (Card Quantity) # <i>Card quantity = number of cards to be enrolled</i>
3. Exit Program Mode	*

ADD OR DELETE A PIN

Programming Step	Keystroke Combination
1. Enter Program Mode	* (Master Code) #
2. Add a PIN <i>Assigns PIN to user ID number</i> OR 2. Delete a PIN <i>Deletes the User ID number and associated PIN</i>	1 (User ID) # (PIN) # <i>Repeat Step 2 for additional PINs</i> 2 (User ID) # <i>Repeat Step 2 for additional PINs</i>
3. Exit Program Mode	*

CHANGE A PIN

This operation is executed from outside of Program Mode.

Programming Step	Keystroke Combination
1. Change a PIN	* (User ID) (Old PIN #) (New PIN #) (New PIN #)

DELETE USER CARD(S)

Programming Step	Keystroke Combination
1. Enter Program Mode	* (Master Code) #
2. Delete Card - By User ID OR 2. Delete Card - By Card OR 2. Delete Card -By Card Number	2 (User ID) # <i>Deleting by User ID number will clear cards and PINs</i> 2 (Read Card) # <i>Requires the user card. Deletes ONLY the card number</i> 2 (Card Number) # <i>Deletes ONLY the card number †</i>
3. Exit Program Mode	*

† BLOCK LEARN DIRECT ENTRY

Format for programming specific Card Numbers: Facility Code + ID Number (including leading 0's) Example: FAC- 24, ID- 100 would be entered as:

26 Bit: 02400100

30 Bit: 002400100

PROGRAMMING

ACCESS CONFIGURATION: CARD ONLY

USING MANAGER CARDS

KPR2000 managers can use manager cards to program user cards into and out of the system. There are two pre-programmed manager cards (an Add Card, and a Delete Card) to allow rapid card enrollment. This is a form of Auto User ID enrollment and is only available in "Card Only" configuration.

Programming Step	Keystroke Combination
Add a User Card	1. (Read Manager Add Card) 2. (Read User Card) <i>Repeat Step 2 for additional user cards</i> 3. (Read Manager Add Card)
Delete a User Card	1. (Read Manager Delete Card) 2. (Read User Card) <i>Repeat Step 2 for additional user cards</i> 3. (Read Manager Delete Card)

ACCESS CONFIGURATION: CARD + PIN

ADD A CARD + PIN USER

Programming Step	Keystroke Combination
1. Enter Program Mode	* (Master Code) #
2. Add a User Card <i>Assigns card number to User ID</i>	1 (Read Card) # OR 1 (User ID) # (Read Card) #
3. Exit Program Mode	*
4. Add PIN	* (Read Card) (1234#) (New PIN #) (New PIN #) <i>This operation is executed from outside of Program Mode</i>

CHANGE PIN

Allows card user to update the PIN for their card + PIN User ID. *This operation is executed from outside of Program Mode.*

Programming Step	Keystroke Combination
1. Change PIN using a Card	* (Read Card) (Old PIN #) (New PIN #) (New PIN #)
OR	
1. Change PIN using PIN	* (User ID) (Old PIN #) (New PIN #) (New PIN #)

DELETE CARD BY USER ID

Deleting by ID number will clear cards and PINs.

Programming Step	Keystroke Combination
1. Enter Program Mode	* (Master Code) #
2. Delete User Card by User ID	2 (User ID) #
3. Exit Program Mode	*

ADVANCED PROGRAMMING

Panic Codes

There is a section of the KPR2000 memory set aside specifically for cards and PINs to be used in the instance of an emergency. There are several rules that guide the use of these cards/PINs:

- Panic Codes activate the relay and the alarm/alarm output.
- Panic Codes use a User ID of 2001~2010 ONLY.
- Panic Codes must be unique. Duplicated Codes act as a normal User Code.

ADD OR DELETE A PANIC PIN

Programming Step	Keystroke Combination
Panic PIN Codes: Add or Delete a PIN	
1. Enter Program Mode	* (Master Code) #
2. Add a PIN	8 (User ID Number) # (PIN) #
OR	
2. Delete a PIN	2 (User ID Number) #
3. Exit Program Mode	*

ADD OR DELETE A PANIC CARD

Programming Step	Keystroke Combination
1. Enter Program Mode	* (Master Code) #
2. Add a User Card	8 (User ID Number) # (Card) #
OR	
2. Delete a User Card	2 (User ID Number) #
3. Exit Program Mode	*

ADVANCED PROGRAMMING

Alarm

TO RESET THE ALARM

Programming Step	Keystroke Combination
To reset the door forced open warning	(Read valid card) OR (Master Code #)
To reset the door open too long (DOTL) warning	(Read valid card) OR (Master Code) #

ANTI-TAMPER ALARM

The KPR2000 uses an optical sensor as the input for its internal alarm. If the case is opened while the KPR2000 is powered, the alarm will operate. To silence, enter a valid credential or cycle power.

Reset the KPR2000

This will reset the KPR2000 to the factory default but all card/PIN information will still be retained. This will also require reprogramming of the Master Add and Delete Cards. **NOTE:** This is useful if the original Master Add and Delete Cards have been lost.

1. Power the KPR2000 down.
2. Press and hold the * button while power is restored to the KPR2000.
3. Release the button and wait until the amber LED shines.
4. Present any 26 bit proximity card or the Manager Add Card (provided) to the KPR2000. This card is now the Manager Add Card.
5. Present any 26 bit proximity card or the Manager Delete Card (provided) to the KPR2000. This card is now the Manager Delete Card.

When the red LED begins to blink, the KPR2000 has been successfully reset.

Erase all Codes

This will delete ALL User data.

1. Enter Program Mode by pressing: * (Master Code) #.
2. Press 2 0000 #.

All configuration data is retained.

Sound & Light Indication

Operation Status	Red LED	Green LED	Amber LED	Sounds
Power On	Flashing			Short Single Beep
Standby	Flashing			
Press Keypad	Flashing			Short Single Beep
5 Second Time-out	Flashing			3 Short Beeps
Enter Master Code Entry Mode	ON			Short Single Beep
In Program Mode	ON	Single Flash		Short Single Beep
Entered Single Program Step Successfully	ON	Single Flash		Short Single Beep
Entered Continuous Program Step Successfully		Single Flash	ON	Short Single Beep
Entered Program Step Incorrectly			ON	3 Short Beeps
Exited from Program Mode	Flashing			Short Single Beep
Entry Granted		ON		Short Single Beep
Alarm Mode Engaged	Flashing			Alarm
Pressing * Toggles Standby/Master Code Entry	ON/Flashing			Short Single Beep

**FOR TECHNICAL SUPPORT DIAL OUR TOLL FREE NUMBER:
1-800-528-2806**